

TMX138 电动滚筒 TMX138 Drum Motor

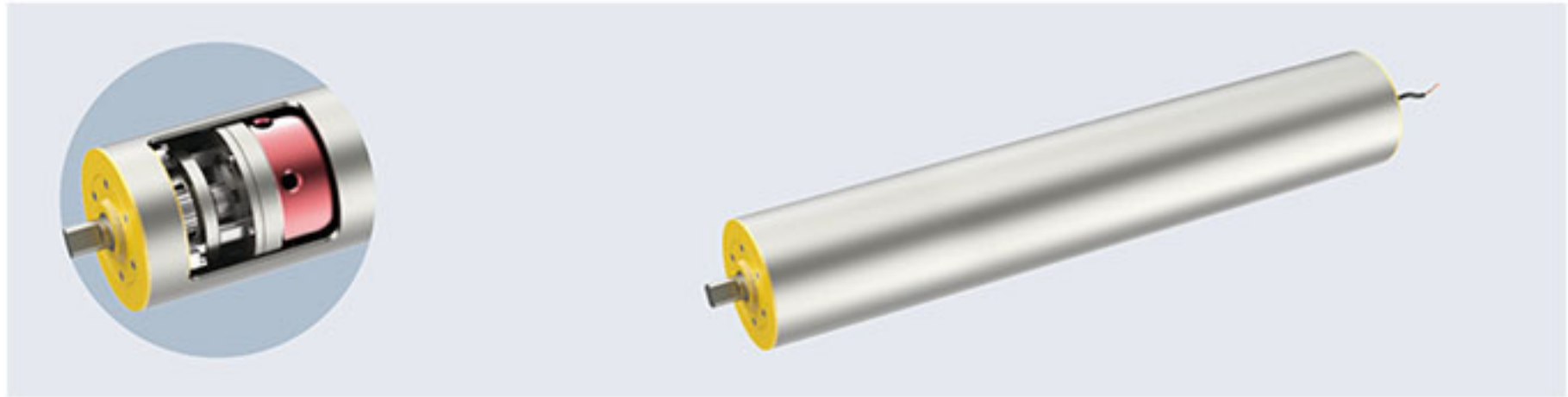

■ 产品概述 Product Description

以高效率、大功率且运转平稳而著称的 TMX138 电动滚筒，此款电动滚筒的功率和速度范围很广，是名副其实的全能型电机。

• 高负载循环输送机 • 食品加工行业 • 制药行业 • 肉禽加工业 • 皮带输送机 • 机场行李处理系统 • 安检机 • 邮政分拣 • 物流应用 • 干燥、潮湿及需要冲洗的应用环境

TMX138 electric drum, which is famous for its high efficiency, high power and stable operation, is a very wide range of power and speed.

• High load cycling conveyer • Food processing industry • Pharmaceutical industry • Meat processing industry • Belt conveyer • Airport baggage handling system • Security machine • Postal sorting • Logistics application • Dry, wet and need to develop the application environment

■ TMX138 电动滚筒特征 TMX138 Characteristics Of Drum Motor

筒体 Drum Shell

- 标准筒体为低碳钢材质，成品表面镀锌，做环保标志
- 标准筒体表面加工防滑螺纹
- 食品级筒体为 304 不锈钢
- Material of standard drum shell is mild steel, zinc plated, with ECO mark.
- Standard cylinder surface processing with non slip roller
- Food grade shell is 304 stainless steel

齿轮传动 Gear Drive

- 高合金钢精磨齿轮，确保传动时超低噪音
- 重载型电动滚筒采用行星齿轮传动，根据重型载荷设计，高扭矩传输
- High alloy steel grinding gear, to ensure the transmission of ultra low noise
- Heavy load electric roller adopts planetary gear transmission, according to heavy load design, high torque transmission

电机 Motor

- 频率在 50Hz 或 60Hz 时，适用于全球各种通用电压
- 电机绝缘等级 F 级。所有电机附加过热保护器。电机油浸式散热
- 电缆出线式，电缆的标准长度 1.2 米
- When 50Hz or 60Hz is used, it can be applied to all kinds of universal voltage.
- Motor insulation class F. All motor additional overheat protector. Oil immersed motor cooling
- Cable outlet type, cable length of 1.2M

密封等级 Seal Level

- 轴端采用双密封设计，电动滚筒的密封防护等级为 IP66/IP67
- Double seal design for shaft end. Drum motor sealing protection level is IP66/IP67

注油 Oiling

- 电动滚筒出厂前都已按标准注油，每运行 10000 小时换油一次
- Electric roller factory before has according to the standard oil. Every 10000 hours to run oil change time

其他 Other

- 水平安装。可以加装电磁制动器，但筒体的最短长度会相应加长
- 带速及筒体长度可按客户要求制作
- 根据客户要求，可制作各种非标准电动滚筒
- Horizontal installation. Can be equipped with electromagnetic brake, but the shortest length of the cylinder will be extended accordingly
- Belt speed and tube length can be produced according to customer requirements
- According to customer requirements, can produce a variety of non - standard electric roller

■ TMX138 三相滚筒电机机械参数 TMX138 Mechanical Parameters Of Three Phase Drum Motor

额定功率 P _N Rated Power P _N kW	电机极数 Motor Series	齿轮箱级数 Gear Box Series	减速比 i Reduction Ratio i	额定转速 n _N Rated Speed n _N RPM	额定线速度 V Rated Speed V m/s	额定扭矩 M _N Rated Torque M _N Nm	牵引力 F _N Traction Force F _N N	最小筒长 L Min Tube Length L mm			
0.37	4	2	9.36	150.00	1.08	21	304	360			
			11.86	118.00	0.85	26	377	360			
			13.68	102.00	0.74	30	435	360			
			17.78	79.00	0.57	39	565	360			
			19.72	71.00	0.51	44	638	360			
			24.98	56.00	0.4	55	797	360			
			28.83	49.00	0.35	64	928	360			
			37.48	37.00	0.27	83	1203	360			
			47.04	30.00	0.22	104	1507	360			
0.55	4	1	5	282.00	2.04	18	261	345			
			6.36	222.00	1.6	15	217	345			
		2	9.36	151.00	1.08	31	449	360			
			11.86	119.00	0.86	39	565	360			
			13.68	103.00	0.74	45	652	360			
			17.78	79.00	0.57	58	841	360			
			19.72	72.00	0.52	65	942	360			
			24.98	56.00	0.41	82	1188	360			
			28.83	49.00	0.35	95	1377	360			
			37.48	38.00	0.27	123	1783	360			
			47.04	30.00	0.22	154	2232	360			
			0.75	4	1	5	282.00	2.04	24	348	385
						6.36	222.00	1.6	15	217	385
2	9.36	151.00			1.08	42	609	400			
	11.86	119.00			0.86	53	768	400			
	13.68	103.00			0.74	61	884	400			
	17.78	79.00			0.57	79	1145	400			
	19.72	72.00			0.52	88	1275	400			
	24.98	56.00			0.41	112	1623	400			
	28.83	49.00			0.35	129	1870	400			
	37.48	38.00			0.27	168	2435	400			
	47.04	30.00			0.22	210	3043	400			
	1.1	4			1	5	282.00	2.04	35	507	415
						6.36	222.00	1.6	45	652	415
2			9.36	151.00	1.08	61	884	430			
			11.86	119.00	0.86	78	1130	430			
			13.68	103.00	0.74	90	1304	430			
			17.78	79.00	0.57	117	1696	430			
			19.72	72.00	0.52	129	1870	430			
			24.98	56.00	0.41	164	2377	430			
			28.83	49.00	0.35	189	2739	430			
			37.48	38.00	0.27	246	3565	430			

■ TMX138 外形图 TMX138 Outline Dimensions

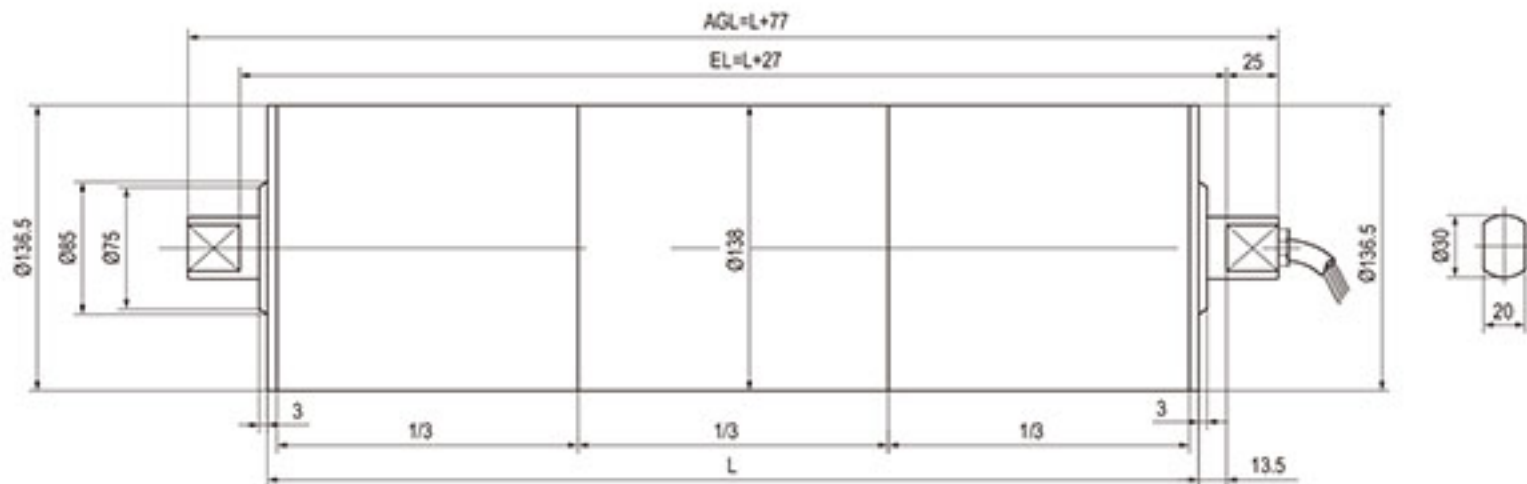

■ TMX138 选项表—电动滚筒 TMX138 Option - Drum Motor

部件说明 Component Description	电动滚筒 Drum Motor
筒体 Drum shell	
碳钢冠状筒体 Carbon steel tube body	1
碳钢直式筒体 Carbon steel straight drum	2
不锈钢 (标准 304) 冠状筒体 Stainless steel (standard 304) coronal tube body	2
不锈钢 (标准 304) 直式筒体 Stainless steel (standard 304) straight drum	2
特殊冠状及凹槽型 Special coronal and groove type	3
前后端盖 Front end cover	
铸铝端盖 Cast aluminum cover	1
镀镍铸铝端盖 Nickel plated aluminum cover	2
不锈钢 (标准 304) 端盖 Stainless steel (standard 304) end cover	2
前后轴 Front and rear shaft	
碳钢轴 Carbon steel shaft	1
不锈钢轴 Stainless steel shaft	2
电机 Motor	
单相或三相异步电动机 Single phase or three phase asynchronous motor	1
电压 1*220V/50Hz 或 3*380V/50Hz Voltage 1*220V/50Hz or 3*380V/50Hz	1
50Hz 或 60Hz 条件下的全球通用电压 Global common voltage under 50Hz or 60Hz conditions	1
加装电机过热保护器 Thermal protector	1
低温环境用油 Low temperature environment	2
食品级油 & 脂 (FDA 和 USDA) Food grade oil & fat (FDA and USDA)	2
电气连接 Electrical connection	
不锈钢弯头 Stainless steel elbow	3
直弯式出线 Straight curved line	1
PVC 线缆 PVC cable	1
低烟无卤素线缆 Low smoke halogen free cable	2
铸铝端子盒 Cast terminal box	1
镀镍铸铝端子盒 Nickel plated aluminum terminal box	1
不锈钢端子盒 Stainless steel terminal box	1
其他选项 Other options	
电磁制动器 Electromagnetic stop device	2
可垂直或倾斜安装 Vertical or inclined installation	3
连接变频器 Connected converter	2

备注 Note:

1 - 标准装配选项 Standard option 2 - 非标准常用选项 Non-standard option 3 - 限制性选项, 选择时应与制造商确认 Restrained option, contact manufacturer if needed

• TMX113 / TMX138

直式出线
Straight outlet

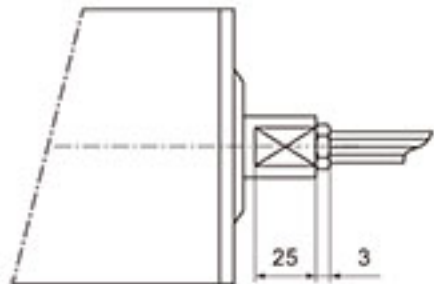

接线端子盒
Terminal box

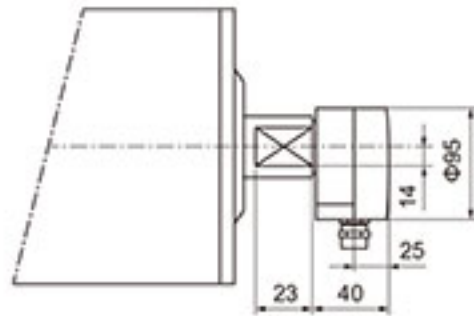

不锈钢弯头出线
Stainless steel elbow outlet

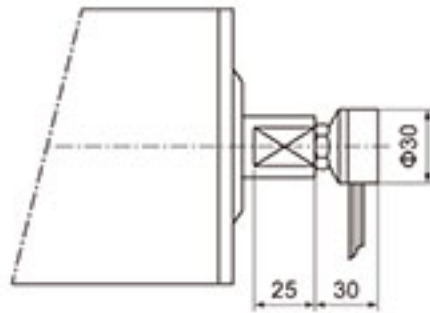

弯式出线
Curved outlet

